

VERIFICATION OF BRAKING MECHANISM OF HOISTING DEVICE BLIND SHAFT NO.11 OF THE MINING PLANT LONEA

PhD, Eng., Assoc. Lecturer, Răzvan Bogdan ITU, Department of Industrial Mechanical Engineering and Transport, University of Petroșani, raz.van4u@yahoo.com

PhD, Eng, Lecturer, Vilhelm ITU, Department of Industrial Mechanical Engineering and Transport, University of Petroșani, drituv@yahoo.com

***Abstract:** Every extraction machine is endowed with a braking system while ensure the right movement of the hoisting vessels, or allows to stop the machine in a certain position of the vessels (brake tests) and the automatic brake device, independently of the operator will, in one of the following situations, considered to be perturbations or damages: tension absence, pressure drop of the working fluid in the braking system circuit, the overraising of the extraction vessels, exceeding the limit speed, overload etc. (safety-braking). Speed decrease made by the brake system must be between 1,5–5 m/s² and the delay length of the brake (from the action release till the effective application) at the most 0,7 s. Constructively, the brake system consists of two components: the working mechanism and the actuating system. Upon the working system, the common brakes can be with disk or with shoes, and from the point of view of actuation, can be with weights and, spring assembly, pneumatics, hydraulics and combined. Braking-mechanism diagnosis for the mi-ning hoisting machines consists in establishing the real safety factors when the safety-brake is applied and when operating brake is applied too. The experimental measurements have been made at the Auxiliary Blind Shaft no.11 at Lonea Mining Plant in order of examination and regulation the hoisting machine.*

Keywords: Diagnosis, Braking mechanism, Hoisting installation;

Introduction

The fundamental elements of hoisting machine placed on the mining surface (fig.1) are: the shaft tower 1; the counterfort 2; the pulleys 6; the rope 7; the hoisting vessels 8 and the winding machine consisting of the wrapping devices of the rope 3 (in given case the drums); the reducing-gearbox 4 and the engine 5.

The hoisting facility works as follows: when the wrapping-device is actuated by the engine, one The two hoisting vessels reaching the level ramps, the loading and unloading operations are taking place simultaneously and after that the entire cycle is repeated.

Every extraction machine is endowed with a braking system (fig.2) while ensure the righthovement of the hoisting vessels, or allows to stop the machine in a certain position of the vessels (brake tests and the automatic brake device, independently of the operator will, in one of the following situations, considered to be perturbations or damages: tension absence, pressure drop of the working fluid in the braking system circuit, the overraising of the extraction vessels, exceeding the limit speed, overload etc. (safety-braking)). Speed decrease made by the brake system must be between 1,5–5 m/s² and the delay length of the brake (from the action release till the effective application) at the most 0,7 s.

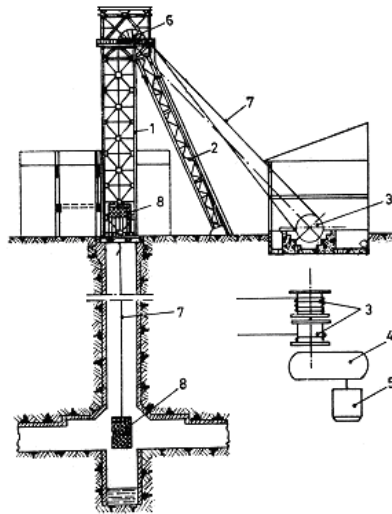

Fig.1. The principle draft of the extraction installation

The working mechanism

Constructively, the brake system consists of two components: the working mechanism and the actuating system. Upon the working system, the common brakes can be with disk or with shoes, and from the point of view of actuation, can be with weights and, spring assembly (fig.2), pneumatics, hydraulics and combined.

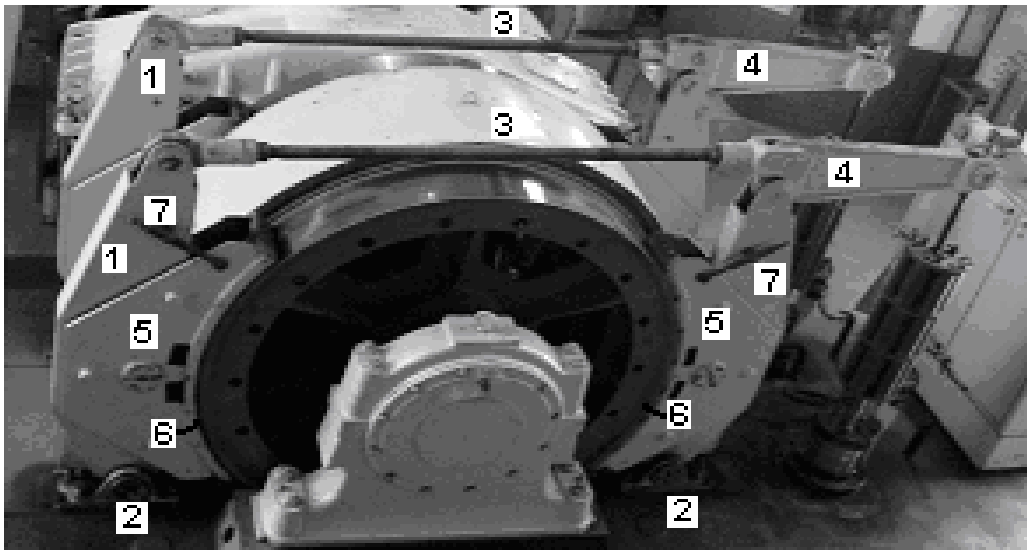

Fig.2. Braking–device extraction – machine

The working mechanism of the brakes with shoes and levers (fig.3) consists of two support beams (1), articulated in joints (2) connected each other through the rod (3) actuated by raising or lowering the lever (4). On the support bars there are fixed the supports (5) of the brake shoes (rigid in case of angular movement and articulated in case of parallel motion).

On the inner side surface of the supports the shoes are fixed (6) with action straight about the brake system. The shoes motion during the braking time is stopped by the joints (7) at the ends of the supports (5).

The installation taken into study

The extracting installation which works on auxiliary blind shaft no.11, from Lonea Mining Plant, which is destined for the underground supply with materials and tools as well as for transporting personal. The personal and materials transport is done to and among levels 300, 400, 480, 650 and 690. The extracting installation that supplies the well (fig.3) is unbalanced (without a balance cable) and has an extracting machine type 2T-3,5x1,8 (fig.4) equipped with two asynchronous motors type AKH2-16-39-12YXP4, of 500 kW power and a nominal rpm of 490 rot/min.

The extracting cables with diameters of Φ 44 mm and a mass (on a linear meter) of 7,05 kg/m on the left branch (from the extracting machine to the well) and Φ 44 mm and a mass 7,03 kg/m on the right branch are wrapped around the two extracting pulleys of Φ 4000 mm with a mass (the pulley, the axel of the pulley and the bearing of the axel) of 1850 kg, laying on the tower at a height of 22,95 m (pulley axel)



Fig.3. Extracting installation

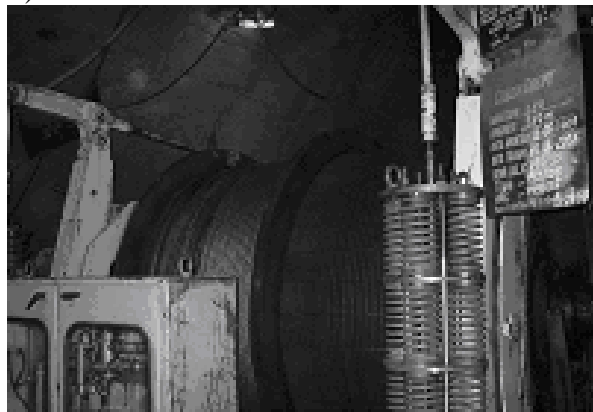

Fig.4. Extracting machine

The cables are wrapped in a single layer (row) on each of the two wheels (wrapping organ (fig.4)) of the machine, from which one is fixed and one is mobile and which are hooked at one end by the exterior end (side margin) of them. The other end of the cables going through the extracting pulleys is hooked to the extracting vessel through the cable tie device (D.L.C.).

The extracting vessels are untopping cages with two levels, with two trolleys each level having a mass (own mass plus D.L.C.) of 4924 kg.

The mass of a trolley is of 650 kg, and the effective load is 1800 kg/trolley. Another main component of the extracting installation is the metallic tower with a height until the pulley axel of 22,95 m.

The structure of the shaft is composed of the extracting pulley platform sustained by the leading component.

The extracting machine lies on the ground (at a height of 3,695 m to the 0 level of the well (well collar)), side ways from the tower (well tower), at a distance (of the wheel axel), towards the vertical portion of the extracting cables which enter the well of 32m.

The length of the cable chord (the distance between the tangent points of the cable to the deviating pulley from the tower and the wheel of the extracting machine, in the central position of the chord (perpendicular on the wheel axel)), is for the left branch $L_{cs}=35,450\text{m}$, and $L_{cd}=35,646\text{m}$ for the right branch.

The incline angles of the cables chords are $\beta_s = 380\ 43'\ 55''$ for the left branch and $\beta_d = 330\ 05'\ 43''$, for the right branch, and the deviating angles (which are formed in the limit positions of the cable chord towards the interior side (interior angle) or exterior (exterior angle) of the wheel, over the central position of the chord) are: $\alpha_{st} = 10\ 8'\ 53''$ și $\alpha_{st} = 00\ 42'\ 11''$ For the left branch and $\alpha_{dr} = 10\ 40'\ 33''$ and $\alpha_{dr} = 00\ 39'\ 43''$ for the right branch.

Operating conditions required for the braking device

Braking momentums, both for maneuver and for safety braking should be at least three times the static momentum:

$$M_{fr} \geq 3M_{st} \text{ [Nm]} \quad (1)$$

In case of an unbalanced winding engines (no compensation cable(balance)), static momentum is:

$$M_{st} = g(Q_u + qH)R \text{ [Nm]} \quad (2)$$

Where g is gravitational acceleration, $g=9,81[m/s^2]$; Q_u useful mass of extraction vessel, kg; q weight per linear meter of extraction cable, kg/m; H extraction depth, m; R is radius of the winding part, m.

For a statically or dynamically balanced installation (with compensation cable):

$$M_{st} = g(Q_u + (q - q_1)H)R \text{ [Nm]} \quad (3)$$

where q_1 is mass per linear meter of compensation cable, kg/m.

In case of adjusting drum position as to another, in changing the hoisting level,

$$M'_{fr} \geq 1,2 M_{1st} \text{ [Nm]} \quad (4)$$

braking momentum will be developed on the fixed drum rim, where M_{1st} is static momentum of a cable branch, generated by the weight of the empty extraction vessel and the extraction cable, Nm

$$M_{1st} = g(Q_c + qH)R \text{ [Nm]} \quad (5)$$

where Q_c is mass of the empty extraction vessel, kg.

Maximum distance between shoes and braking rim should be no more than 2 mm.

A deceleration of at least $1,5\ m/s^2$ and at most $4-5\ m/s^2$ is also required during braking, but the critical magnitude when driving wheel winding installation cables slide shall not be exceeded.

The mechanism diagnosis

Braking–mechanism diagnosis for the mining hoisting machines consists in establishing the real safety factors when the safety–brake is applied and when operating brake is applied too.

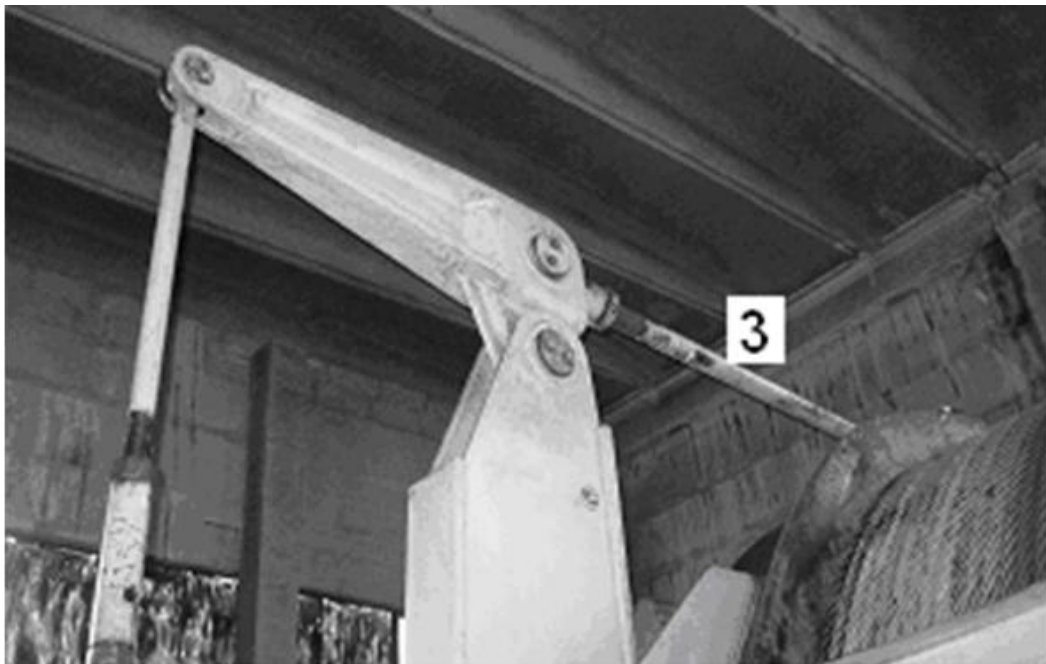

Fig.5. Tirant left wit tension metres marks



Fig.6. Tirant reight wit tension metres marks

For the experimental checking of the effective forces of stretching from the tyrants (in the rods 3), and the estimation of the real safety coefficients, two strain gauges have been stuck together on each tyrant (fig.5 and fig.6), diametrically contrariwise, in order to eliminate the bending-effect and by means of other two compensation gauges it has been made up a Wheatstone bridge with two active branches and two passive ones.

The experimental measurements have been made at the auxiliary Blind Shaft number 11

at Lonea Mining Plant in order of examination and regulation the hoisting machine.

The values of forces from the tyrants, by means of which the safety coefficients have been calculated were obtained as following the measurements performed during the extraction cycle, together with kinematic elements of the vessels motion / movement on the shaft – raising have been rendered in fig.7 and fig.8.

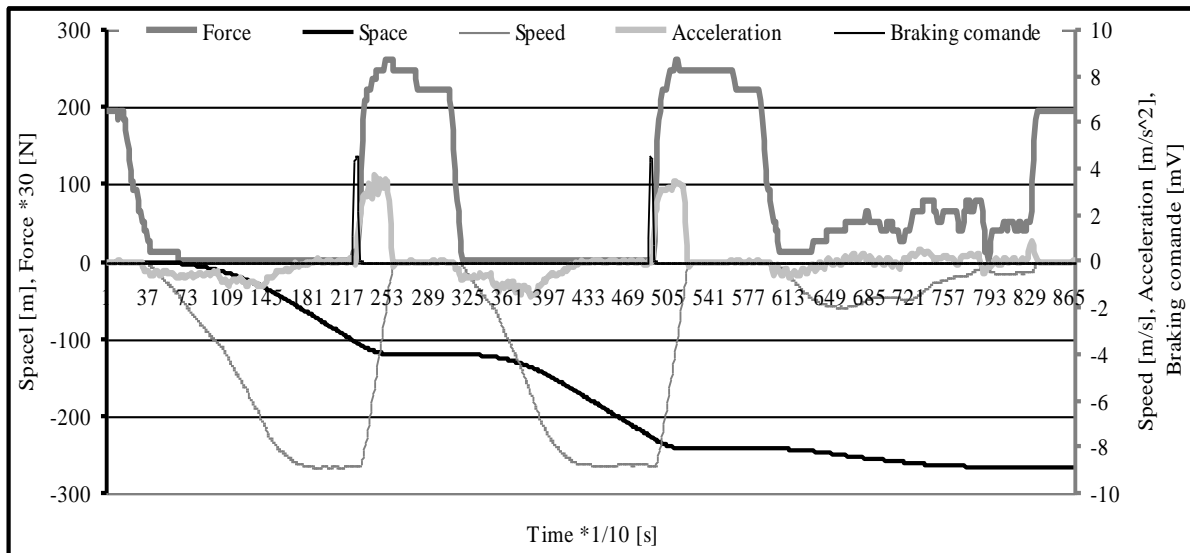

Fig.7. Right tie bar, left skip going down

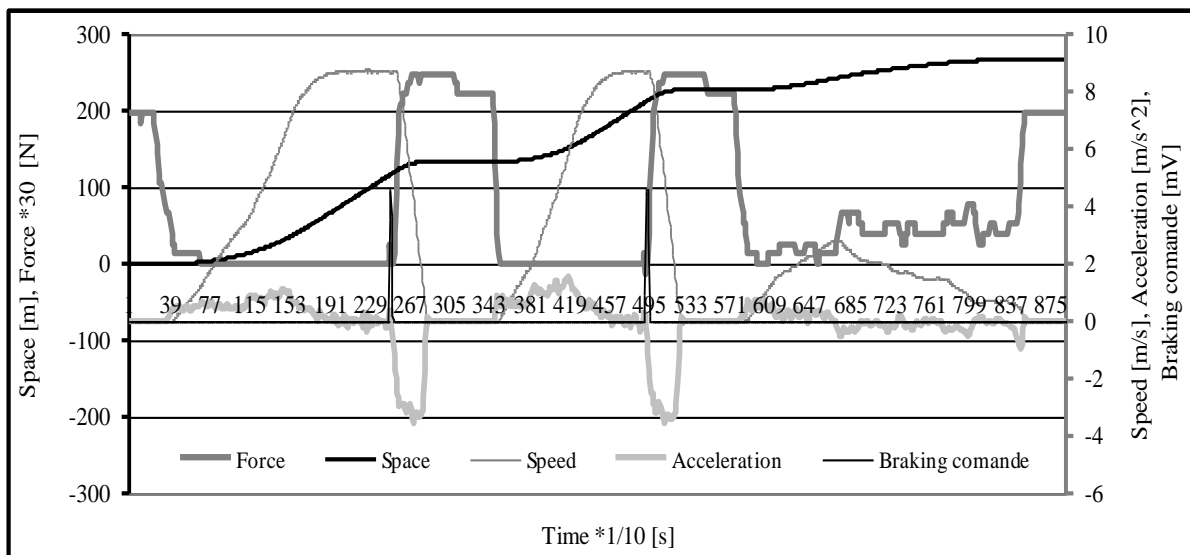

Fig.8. Right tie bar, left skip going up

Conclusions

Actual safety coefficient calculated with the effective force in the tie bar, found as a result of experimental measurements, in application of safety brake and in application of maneuver brake, is in the admitted range.

Decelerations and delays in the application of safety brakes are also in admitted ranges..

References

- [1] I. Dumitrescu, D. Jula, Elena Rosu (Gîrjob), Lorin Poiana, Miron Lupulescu - *Issues concerning the increase of the uptime for the cylindrical gear that is part of the rotating system of EsRc 1400 bucket wheel excavator*, Annals of the University of Petroșani, Mechanical Engineering, vol 12 (XXXIX), Petroșani, 2010, pag. 81-90, ISSN 1454-9166
- [2] Magyari A., *Instalații mecanice miniere*, Editura Tehnică, București, 1990;
- [3] Ridzi M.C., Zoller C.L., Itu V., Radu D.A., Dobra R., *Metode și principii de măsurare electronică a tensiunilor mecanice*, Editura Universitas, Petroșani, 2005;
- [4] S.C. TECHNOSAM S.R.L., *Expertizarea și reglarea mașinii de extracție tip K 6080 – SR 29*;
- [5] *** *Documentație tehnică*, instalație de extracție de la Exploatarea Minieră Lupeni.